



Airspace Technology Demonstration 2 (ATD-2)

CDM CAT NTML Lessons Learned

October 9, 2019

Bob Staudenmeier



Reduce verbal communication and streamline restriction compliance in the NAS by:

1. Automatic utilization of electronic Traffic Management Initiatives (TMIs)
2. Providing situational awareness of TMIs
3. Providing tools to manage TMIs within the ATD-2 system
4. Interfacing with existing FAA systems to improve the speed and accuracy of decisions related to TMI affected flights
5. Distributing flight and TMI data via TFDM Terminal Publication (TTP) SWIM feed

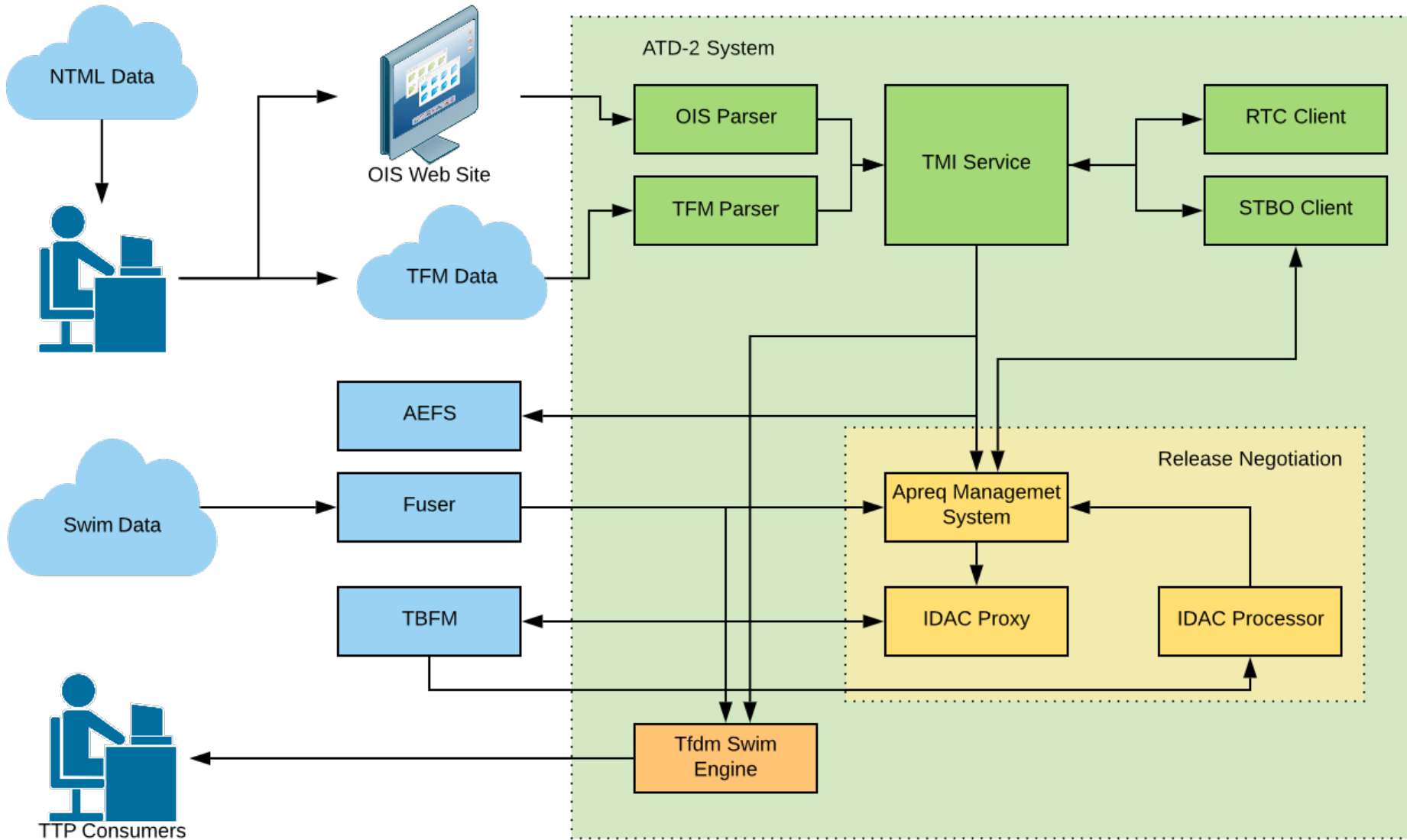



- Restriction column in OIS table is free text
 - Typos in keywords
 - Keywords out of expected order (e.g. start/end time values before APREQ/MIT keyword when they are expected after)
 - Precision matters!

Example: STOP CLT to CLT via NORTH JOJJO 1834-1930 WX:TSTMS ZTL:CLT

- NORTH was interpreted as the closure with JOJJO marked as an inclusion constraint
- Resulted in all fixes in the NORTH departure gate being closed
- TMI was intended to only close JOJJO



- Not all restriction types are available from OIS
- Not all airports/centers publish data to OIS
- OIS page does not display future restrictions
- Restriction only show after they have started
- Lag time between when a restriction goes into affect and when it shows on the OIS page (9 min. average lag)
- Occasional OIS page down time results in missing restrictions
- Unexpected changes to page URL, format, or permissions could result in a loss of data



- APREQs are not currently observed in TFM Flow.
- Manual entry of the restrictions can result in typos that cause difficulties in parsing or dropped data.
- If TMIs are not entered into NTML, they may not end up in TFM Flow. FDIO, phone, or internal systems may be used to distribute TMI information.
- If ATC makes a free text log entry rather than using NTML's restriction panel the automated publishing of the restriction data may not happen.
- Ground Stop advisories are usually generated automatically when a Ground Stop is entered into FSM. However, some stops are initiated verbally with a free-text advisory manually created. These stops will not follow the same format as the automated Ground Stop advisories.
- Requires a well defined and consistent process of generating the TFM messages
- Value added qualifier and remarks fields contain center specific formatting
- Refresh messages are difficult to decipher and match

TMI	OIS	TFM Flow	NTML
Airport Information	NO	YES	YES
Airspace Flow Programs	NO	YES	YES
Ground Delay Programs	NO	YES	YES
Ground Stops	NO	YES	YES
Miles/Minutes in Trail	YES	YES	YES
Altitude Restrictions	YES	YES	YES
APREQs	YES	NO	YES
Advisories	NO	YES	YES
Closures (Fixes, etc.)	YES	YES	YES
FADT	NO	YES	NO
RAPT	NO	YES	NO
CTOP	NO	YES	NO
DICE	NO	YES	NO
REROUTEs	NO	YES	NO
TMI FLIGHT LIST	NO	YES	NO

- A source comparison was conducted, looking at several days' data from the OIS restrictions page, TFM Flow, and NTML entries
- A combination of OIS restrictions page and TFM Flow data was the recommended source
- Later, comparison between TFM Flow and the OIS restrictions page revealed restrictions in TFM Flow messages typically arrived several minutes before the appearing OIS restrictions page. Also, that restrictions only appeared on the OIS page at or after the restriction start time.

Difference Between TFM and OIS
September - November 2017

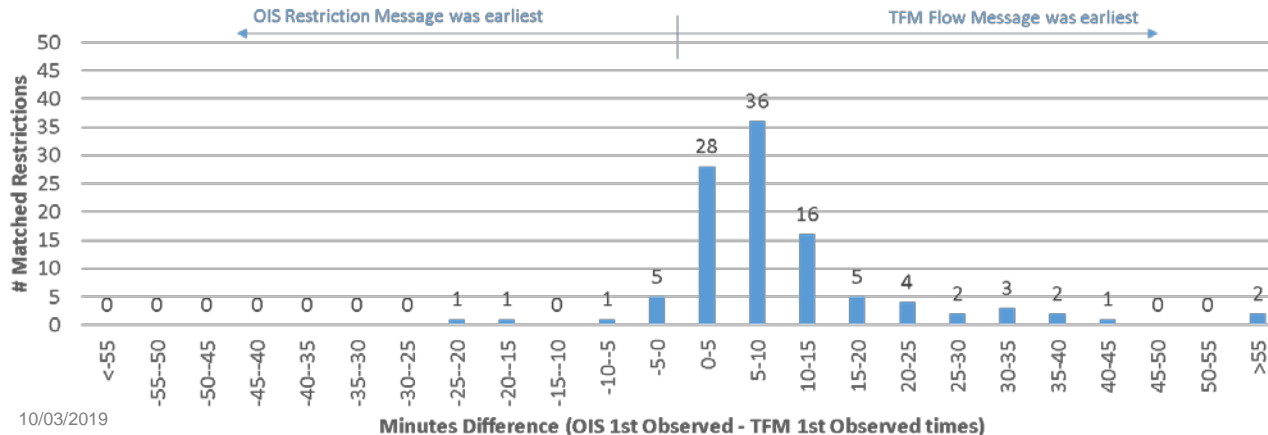

- Authoritative TMI repository across all ATD-2 components
- Processes, stores, de-conflict, and distribute TMI's
- Automatically recognizes and tags flights constrained by an active or future TMI event.
- Support persistent TMI's spanning multiple days (e.g. taxiway closures)
- Handles the following TMI data:

TMI Type	Possible Sources
Runway Utilization	User
APREQs	User, OIS
Surface Metering Programs	Scheduler
Departure Fix Closures	User, TFM, OIS
Departure Gate Closures	User, TFM, OIS
Ground Delay Programs	TFM
Ground Stops	User, TFM
MITs	User, TFM, OIS
Ramp Closures	User
Runway Closures	User
Scheduled Metering Modes	User
Taxiway Closures	User



Misc

RSTN

MRSTN

Delay

RWY

Sum

EQ

Log

MyEntry

SISO

Count

ICE

INFO

MA

PIREP

SUA

SWAP

Telcon

Pending

Request Type: Initiate Modify Cancel Delete

Entry Time: Clear on Submit

Type:
MT:

Aircraft Type:

All Jet Prop Other:

Requesting:
Providing (>):

Start Time:
End Time:
Causal Factor...:

Restriction:

En Route Departure Arrival

Altitude:

Speed:

Airport (>):
Qualifier ():

Via (>):
Exclusions:

Location (>):
 Severe Weather Reroute

Justification/Remarks:

ATCSCC Remarks/Critique:

Send To... ESIS:

Pos:

Fac:

Coordination Complete

Reminder (Z):

Entry #:

Submit
Spelling
Clear
Save As

10/03/2019

TPCOPS

Pending: 5 / 1

9

- The process of TMIs getting to TFM Flow messages is currently being investigated (by observation at D10)
- In general, the process appears to be:
 - TRACON/ARTCC TMC determines need for TMI
 - Requesting facility TMC enters restriction in NTML using the Restriction Panel
 - Automation broadcasts the restriction via TFM Flow

The screenshot shows a web-based form for entering a Traffic Management Initiative (TMI). The form is organized into several sections:

- Header:** Request Type: Initiate Modify Cancel [Other]. Entry Time: 1936. Clear on Submit.
- General Info:** Type: [dropdown] MIT: [text]. Aircraft Type: All Jet Prop Other: [text].
- Requesting/Providing:** Requesting: ZTL. Providing (Z): [dropdown]. Start Time: [text] End Time: [text].
- Restriction:** En Route Departure Arrival. Airport (Z): [dropdown]. Via (Z): WHITE. Location (Z): [dropdown].
- Operational Parameters:** Causal Factor... [text]. Altitude: [text]. Speed: [text]. Qualifier (Z): NONE. Exclusions: [text]. Severe Weather Rep.
- Remarks:** Justification/Remarks: [text area]. ATCSCC Remarks/Critique: [text area].
- Coordination:** Send To... ESIS: [text] Pos: [text] Fac: [text]. Coordination Com... Reminder (Z) [text] Entry #: [text].



2048	3 E MRSSH ON FORCK	VE
2057	2032-2057 BYP: CLSD TO DFW [CANCELLED]	VE
2058	CFR MSP	VE
2058	BYP: DFW 15 MIT	VE
2116	2033-2116 UKW: CLSD TO DAL AND E SAT TRAFFIC [CANCELLED]	VE
2132	W TWR ON VECTORS	VE
2133	2 W HUDAD/HRPER ON KATZZ	VE
2134	JEN DFW BOUNDARY @110	RZ
2207	2048-2207 3 E MRSSH ON FORCK [CANCELLED]	RZ
2207	1 E FORCK 10MIT	RZ
2210	2133-2210 2 W HUDAD/HRPER ON KATZZ [CANCELLED]	RZ
2210	1 W KATZZ	RZ
2210	DR1 VECTORS	RZ
2226	2058-2226 BYP: DFW 15 MIT [CANCELLED]	RZ
2226	BYP DFW STOPPED	RZ
2226	BYP DAL STOPPED	RZ
2242	2210-2242 1 W KATZZ [CANCELLED]	RZ
2242	2 W HUDAD ON HRPER/ KATZZ ON WSTEX	RZ
2314	3 N GRA ON AKU/10 MIT PER	RZ

- TFM Flow data provides added value to the OIS TMI data
- Source for the following TMIs:
 - Restrictions (Type=RSTR)
 - MIT/MINIT
 - Fix Closure (STOP)
 - General Advisories (Type=GADV)
 - Reroutes
 - GDP/GS

Facility	Total RSTR Msg #	MIT Msg #	MINIT Msg #	STOP Msg #
N90	5590	3002	1637	14
PCT	4504	4389	0	114
PHL	1758	1288	0	31
EWR	1496	16	949	19
LGA	1493	13	948	16
HPN	1040	13	548	15
TEB	979	12	531	19
JFK	959	462	3	13
SCT	932	901	16	14
D21	801	785	0	16
DCA	691	622	0	68
NCT	558	524	0	0
IAD	412	343	0	68
I90	391	382	9	0
BWI	375	321	0	53
ATL	267	252	4	11
F11	214	214	0	0
LAS	202	196	0	6
CLT	154	111	1	41
MSP	107	107	0	0
IND	104	104	0	0

Restriction messages by facility, Sep-Nov 2017

Some messages had multiple types in the same message (e.g. MIT and SPD),
A facility was counted if it was requesting or providing, excluded DCC and ARTCCs.



2232	TMNC	APREQ: ATL,CLT to DFW 2100-0000, WX:Thunderstorms ZTL:ATL,CLT, APREQ: MOD	XS
2232	TMNC	CLT Dept via KILNS,BARMY 10 Mit 2045-0000, WX:Thunderstorms ZDC:ZTL,CLT, RSTN: MOD	XS
2247	TMNC	GDP CNX BOS 30/2241Z ADVZY=100 BOS/ZBW 06/30/2019	XS
2255	TMNC	STOP: CLT to CLT via NORTH VIA JOJJO, WEAZL/KRITR NORMAL 2147-0000, WX:TSTMS ZTL:CLT, STOP: MOD/APVD 2248/DCC:NE/VM	XS
2350	TMNC	CLT VMC ARR:36L/36C/36R DEP:36C/36R AAR(Strat/Dyn):87/72 ADJ:Airspace Acceptance/Limitation ADR:60 RMK:LEVEL 4 AND 5 AREAS OF WX THROUGHOUT NORTH QUADRANT OF TRACON AIRSPACE IPACTING ARRIVALS AND DEPARTURES. (updated at 2350 by CLT) FWD:TMDC,DCC,ZTL,ZJX	XS
0004	TMNC	ZTL FLIGHT PLAN DROP INTERVAL IS SET AT 3 HRS MESSAGE 2340-0400, VOL:Volume ZTL:ZDC,ZJX,ZHU,ZID,ZME,ATL,CLT, RSTN: APVD 2358/DCC:NE/RT	XS
0004	TMNC	CANCELLED: CLT Dept via KILNS,BARMY 10 Mit 2045-2346, WX:Thunderstorms	XS

NTML: ZFW STMC 30 Sep 2019 1817

Options Edit View Tools Information Print Reports Link Search Help

Log
SISO
Misc
RSTN
Delay
RWY
Sum
MRSTN
MyEntry
MA
SWAP
INFO
Pending

Mike Spurgeon Request Type: Initiate Modify Cancel Delete

Entry Time: 1817 Clear on Submit

Type: MIT: 10

Aircraft Type:
 All Jet Prop Other:

Requesting: ZFW
 Providing (/): D10

Start Time: 1900 End Time: 2100 Causal Factor... WX:Thunderstorms

Restriction:
 En Route Departure Arrival

Altitude:
 Speed:
 Qualifier (/): ON ZACHH

Airport (/):
 Via (/): TRYTN/FORCK/MRSSH
 Location (/):
 Exclusions:
 Severe Weather Reroute

Justification/Remarks:
 ATCSCC Remarks/Critique:

Send To... ESIS: TMU,DAL Coordination Complete
 Pos: Reminder (Z):
 Fac: Entry #:

Submit Spelling Clear Save As

TPCOPS Pending: 16 / 0

Map

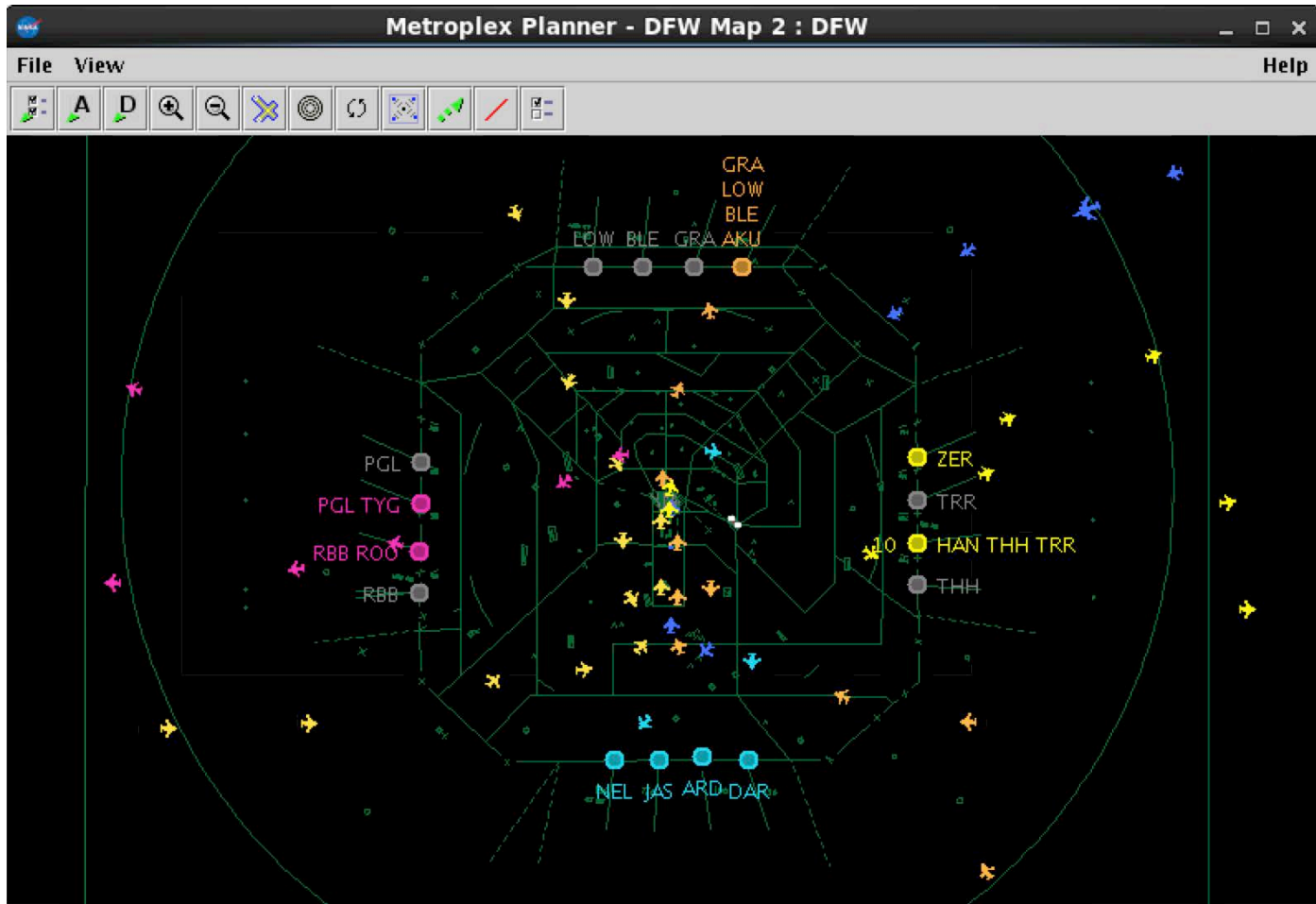



NTML: ZFW STMC 30 Sep 2019 1817
_ □ ×

Options Edit View Tools Information Print Reports Link Search
Help

Log

SISO

Misc

RSTN

Delay

RWY

Sum

MRSTN

MyEntry

MA

SWAP

INFO

Pending

Mike Spurgeon

Request Type: Initiate Modify Cancel Delete

Entry Time: Clear on Submit

Type: MIT:

Aircraft Type:

All Jet Prop Other:

Requesting:

Providing (/):

Start Time: End Time:

Causal Factor...:

Altitude:

Speed:

Qualifier (/):

Exclusions:

Severe Weather Reroute

Restriction:

En Route Departure Arrival

Airport (/):

Via (/):

Location (/):

Justification/Remarks:

ATCSCC Remarks/Critique:

Send To... ESIS: Coordination Complete

Pos:

Fac:

Reminder (Z):

Entry #:

Submit

Spelling

Clear

Save As

SWAP Entries Using RSTN Tab



NTML ENTRIES FOR SWAPS		
FIX/ROUTE CLOSED	WITH QUALIFIER AS	ASSOCIATED FIXES/ROUTES
NELYN/NELYN	SWAP WEST SWAP EAST	RBBIT/WSTEX THHOR/MRSSH
JASPA/JASPA	SWAP WEST SWAP EAST	RBBIT/WSTEX THHOR/MRSSH
ARDIA/ARDIA	SWAP WEST SWAP EAST	RBBIT/WSTEX THHOR/MRSSH
DARTZ/DARTZ	SWAP WEST SWAP EAST	RBBIT/WSTEX THHOR/MRSSH
PGLET/HUDAD	SWAP NORTH SWAP SOUTH	LOWGN/LOWGN NELYN/NELYN
TYGGR/HRPER	SWAP NORTH SWAP SOUTH	LOWGN/LOWGN NELYN/NELYN
ROOOO/KATZZ	SWAP NORTH SWAP SOUTH	LOWGN/LOWGN NELYN/NELYN
RBBIT/WSTEX	SWAP NORTH SWAP SOUTH	LOWGN/LOWGN NELYN/NELYN
LOWGN/LOWGN	SWAP WEST SWAP EAST	PGLET/HUDAD ZERLU/ZACHH
BLECO/BLECO	SWAP WEST SWAP EAST	PGLET/HUDAD ZERLU/ZACHH
GRABE/GRABE	SWAP WEST SWAP EAST	PGLET/HUDAD ZERLU/ZACHH
AKUNA/AKUNA	SWAP WEST SWAP EAST	PGLET/HUDAD ZERLU/ZACHH
ZERLU/ZACHH	SWAP NORTH SWAP SOUTH	AKUNA/AKUNA DARTZ/DARTZ
TRRCH/TRYTN	SWAP NORTH SWAP SOUTH	AKUNA/AKUNA DARTZ/DARTZ
HANUH/FORCK	SWAP NORTH SWAP SOUTH	AKUNA/AKUNA DARTZ/DARTZ
THHOR/MRSSH	SWAP NORTH SWAP SOUTH	AKUNA/AKUNA DARTZ/DARTZ

NTML: ZFW STMC 30 Sep 2019 1816

Options Edit View Tools Information Print Reports Link Search Help

Log
SISO
Misc
RSTN
Delay
RWY
Sum
MRSTN
MyEntry
MA
SWAP
INFO
Pending

Mike Spurgeon Request Type: Initiate Modify Cancel Delete
Entry Time: **1803** Clear on Submit

Type: **STOP** STOP:

Aircraft Type:
 All Jet Prop Other:

Requesting: **ZFW**
Providing (/): **ZME**
Start Time: **1804** End Time: **1845** Causal Factor...

Restriction:
 En Route Departure Arrival

Altitude:
Speed:
Qualifier (/): **NONE**
Exclusions: Severe Weather Reroute

Airport (/): **DFW**
Via (/):
Location (/):

Justification/Remarks:
ATCSCC Remarks/Critique:

Send To... ESIS: Coordination Complete
Pos: Reminder (Z):
Fac: Entry #:

Submit Spelling Clear Save As

Multiple Restrictions Tab



NTML: ZFW STMC 30 Sep 2019 1815

Options Edit View Tools Information Print Reports Link Search Help

Log
SISO
Misc
RSTN
Delay
RWY
Sum
MRSTN
MyEntry
MA
SWAP
INFO
Pending

Mike Spurgeon Request Type: Initiate Modify Cancel Delete
Entry Time: 1815 Clear on Submit

Requesting: ZFW Causal Factor... VOL:Volume
Location: Exclusions:

Incl	Providing	Airport	Via	Rstn	Value	Start	End	AC_Type/Qualifier	Spd	Alt	Ext
<input checked="" type="checkbox"/>	A	ZME	DFW	RRNET	10	1900	2100	RALT	=		AT
<input checked="" type="checkbox"/>	A	ZME	DFW	FEWWW	10	1900	2100	RALT	=		AT
<input checked="" type="checkbox"/>	A	ZHU	DFW	PNUTS	15	1915	2030	RALT	=		AT
<input checked="" type="checkbox"/>	A	ZME	DFW	YUYUN	10	1930	2030	RALT	=		AT
<input type="checkbox"/>	E							ALL	=		AT
<input type="checkbox"/>	E							ALL	=		AT
<input type="checkbox"/>	E							ALL	=		AT
<input type="checkbox"/>	E							ALL	=		AT
<input type="checkbox"/>	E							ALL	=		AT
<input type="checkbox"/>	E							ALL	=		AT

Justification/Remarks Severe Weather Reroute

Send To... ESIS: Pos: Fac: Coordination Complete Reminder (Z): Entry #:

Submit Spelling Clear Save As



MISC and SWAP tab entries do not show up in TFM data. Also, the SWAP tab only allows 1 entry at a time.

RSTN tab is used for all restrictions including SWAP entries

“TXT” under the TYPE does not work. Just like the “CFR” does not come through TFM Flow

A MIT entered under the RSTN tab does come through to TFM flow prior to the TRACON acknowledgement

Have not tested all entries

ESIS Training may be necessary-”different look”

Fix compression caused by weather events near TRACON airspace

Currently

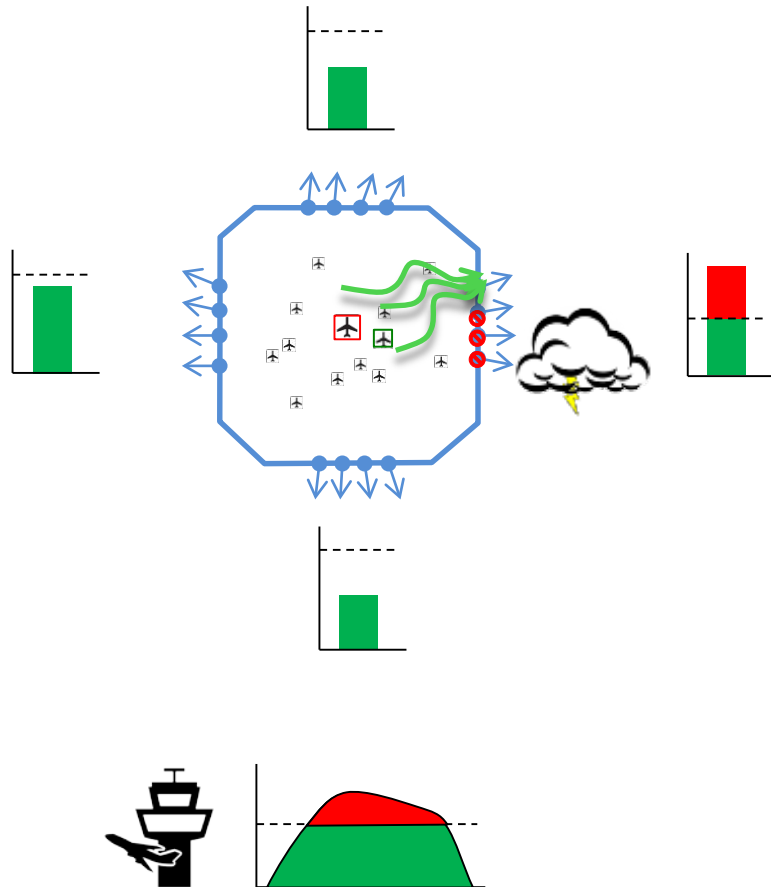

Load Balancing With TOS (Trajectory Option Set)

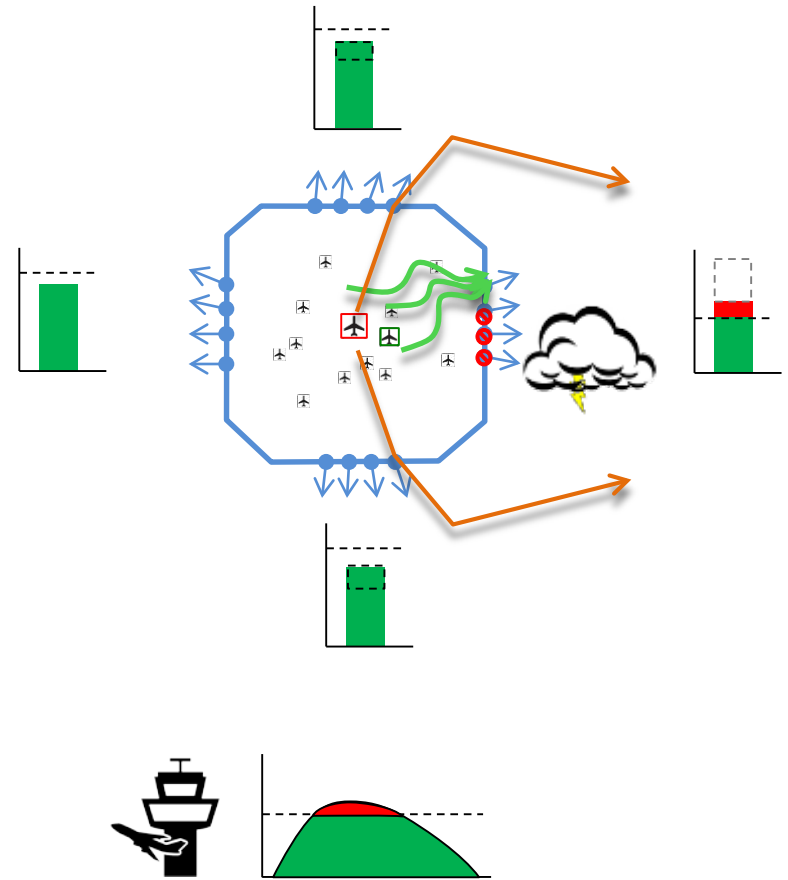

October 2017 departures above 11,000ft

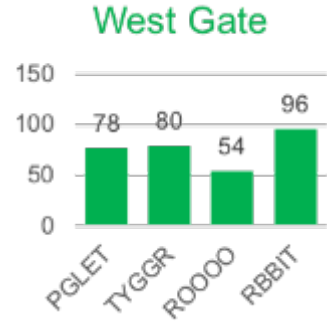

West Gate
306/day

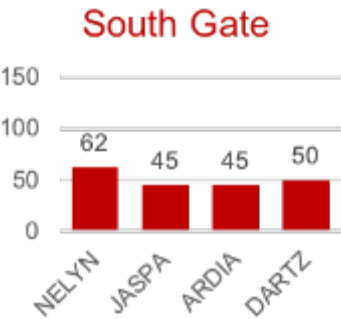

North Gate
252/day

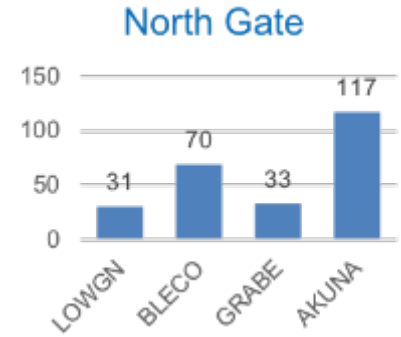
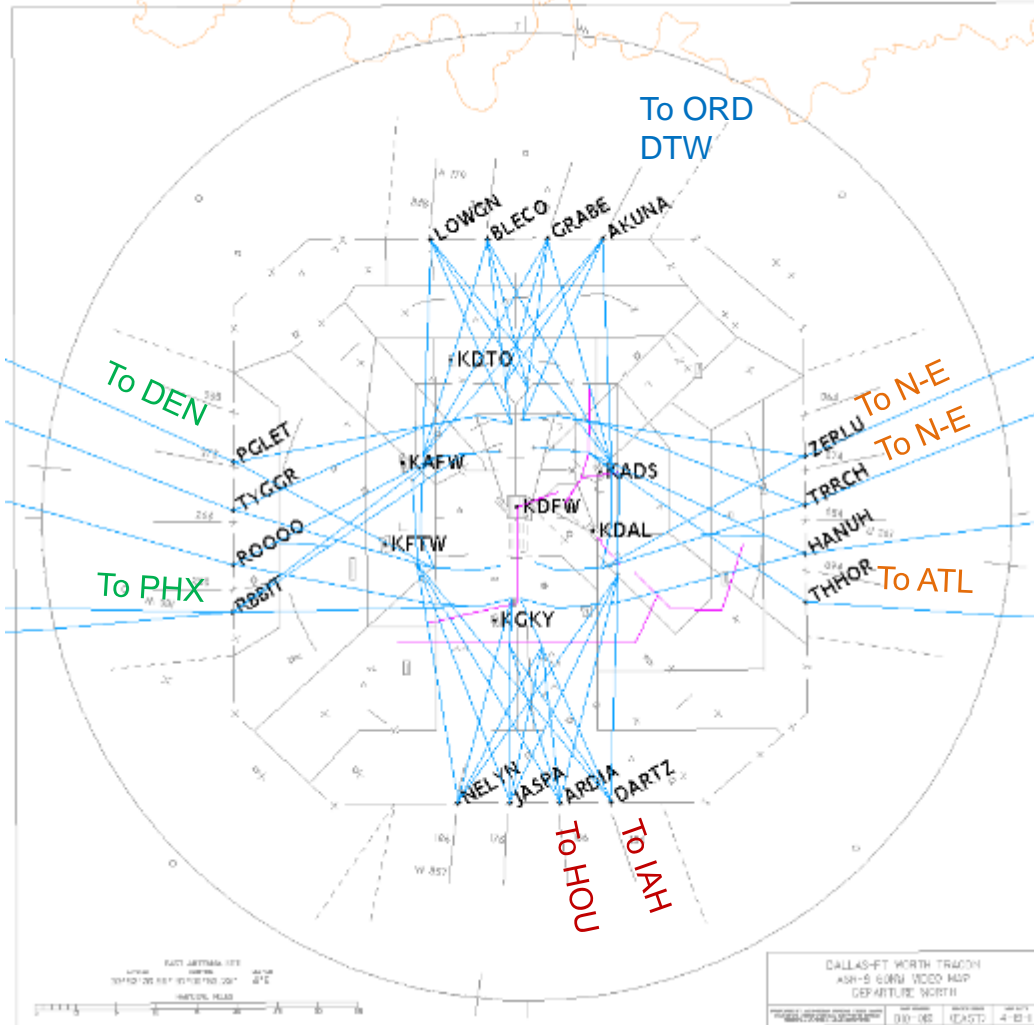

East Gate
435/day

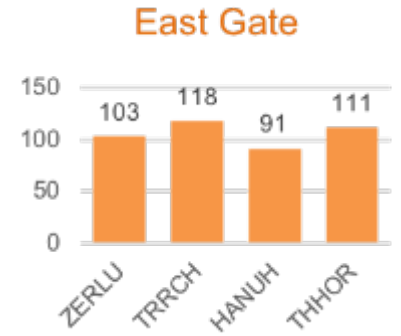

South Gate
201/day

Fix Closures

Creation Time	Start Time	End Time	Actual End Time	End Reason	Duration	Fix	Alt Fix	Alt Gate	Source	Inclusions	Exclusions	Creating User
2019-09-26 06:53	2019-09-26 06:55	2019-09-26 10:30	2019-09-26 10:31	EXPIRED	03:36	GRABE	BLECO	NORTH	TFM			
2019-09-26 09:12	2019-09-26 09:15	2019-09-26 12:15	2019-09-26 09:45	CANCELLED	00:30	HANUH	OTG		TFM			
2019-09-26 09:12	2019-09-26 09:15	2019-09-26 12:15	2019-09-26 09:45	CANCELLED	00:30	THHOR	OTG		TFM			
2019-09-26 09:12	2019-09-26 09:15	2019-09-26 12:15	2019-09-26 09:45	CANCELLED	00:30	ZERLU	OTG		TFM			
2019-09-26 09:45	2019-09-26 09:45	2019-09-26 11:45	2019-09-26 10:14	CANCELLED	00:29	TRRCH	HANUH	EAST	TFM			
2019-09-26 09:45	2019-09-26 09:45	2019-09-26 11:45	2019-09-26 10:14	CANCELLED	00:29	ZERLU	HANUH	EAST	TFM			
2019-09-26 10:14	2019-09-26 10:14	2019-09-26 12:00	2019-09-26 10:59	CANCELLED	00:45	HANUH	THHOR	EAST	TFM			
2019-09-26 10:14	2019-09-26 10:14	2019-09-26 12:00	2019-09-26 10:59	CANCELLED	00:45	TRRCH	ZERLU	EAST	TFM			
2019-09-26 12:35	2019-09-26 12:35	2019-09-26 15:00	2019-09-26 13:54	CANCELLED	01:19	AKUNA	BLECO	NORTH	TFM			
2019-09-26 12:35	2019-09-26 12:35	2019-09-26 15:00	2019-09-26 13:54	CANCELLED	01:19	GRABE	BLECO	NORTH	TFM			
2019-09-26 13:55	2019-09-26 13:55	2019-09-26 17:00	2019-09-26 14:22	CANCELLED	00:27	AKUNA	GRABE	NORTH	TFM			

MIT Restrictions

Creation Time	Start Time	End Time	Actual End Time	End Reason	Duration	Fix	Miles in Trail	Source	Inclusions	Exclusions	Creating User
2019-09-26 06:59	2019-09-26 07:00	2019-09-26 10:00	2019-09-26 07:00	CANCELLED	00:00	HANUH	10	TFM			
2019-09-26 09:45	2019-09-26 09:45	2019-09-26 11:45	2019-09-26 09:46	CANCELLED	00:01	HANUH	10	TFM			
2019-09-26 14:37	2019-09-26 14:35	2019-09-26 15:30	2019-09-26 15:31	EXPIRED	00:56	HANUH	10	TFM			
2019-09-26 14:37	2019-09-26 14:35	2019-09-26 15:30	2019-09-26 15:31	EXPIRED	00:56	THHOR	10	TFM			
2019-09-26 14:37	2019-09-26 14:35	2019-09-26 15:30	2019-09-26 15:31	EXPIRED	00:56	TRRCH	10	TFM			

Ground Delay Programs

Creation Time	Start Time	End Time	Actual End Time	End Reason	Duration	Destination	Requesting Facility	Reason	Source	Inclusions	Exclusions
2019-08-30 09:14	2019-08-30 12:00	2019-08-30 21:59	2019-08-30 19:46	CANCELLED	07:46	EWR	ZNY		TFM		
2019-08-30 13:00	2019-08-30 15:00	2019-08-30 20:59	2019-08-30 20:59	EXPIRED	05:59	DFW	ZFW	THUNDERSTORMS	TFM		
2019-08-30 18:07	2019-08-30 18:15	2019-08-30 19:59	2019-08-30 19:51	CANCELLED	01:36	DFW	ZFW		TFM		

APREQ Restrictions

Creation Time	Start Time	End Time	Actual End Time	End Reason	Duration	Destination	Requesting Facility	Source	Inclusions	Exclusions	Creating User
2019-08-30 06:41	2019-08-30 06:41		2019-08-30 19:59	CANCELLED	13:17	IAH		USER			MP DFW
2019-08-30 07:02	2019-08-30 07:02		2019-08-31 03:00	EXPIRED	19:57	DAL		USER			MP DFW
2019-08-30 07:02	2019-08-30 07:02		2019-08-30 08:29	CANCELLED	01:26	DEN		USER			MP DFW
2019-08-30 11:11	2019-08-30 11:11		2019-08-30 17:09	CANCELLED	05:58	DEN		USER			MP DFW
2019-08-30 17:09	2019-08-30 17:09		2019-08-30 19:59	CANCELLED	02:49	HOU		USER			MP DFW



NASA and the FAA are collaborating to provide a prototype TFDM Terminal Publication (TTP) feed via SWIM R&D network as part of the ATD-2 Field Demonstration

Applications that Leverage the TTP Prototype Feed

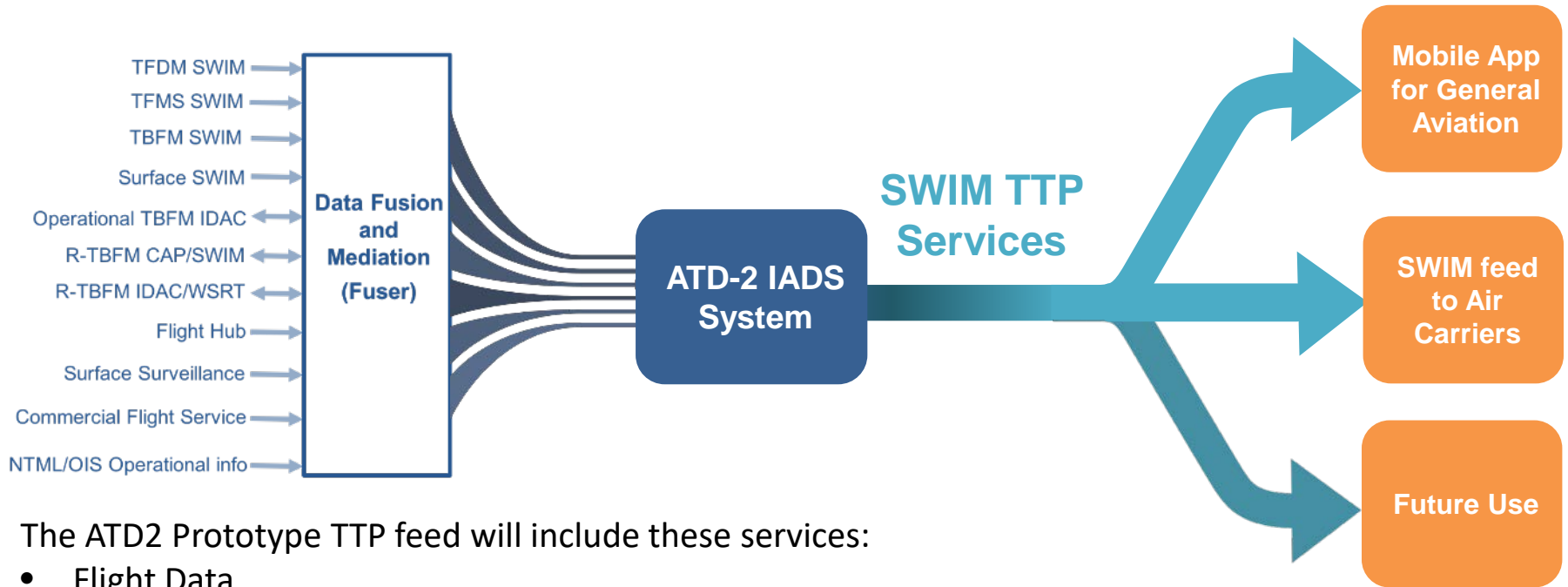

The ATD2 Prototype TTP feed will include these services:

- Flight Data
- Airport Information
- Traffic Management Restrictions
- Flight Delay
- Surface Metering Program
- Operational Metrics

TTP is now available on SWIM R&D for CLT. You are welcome to onboard now!

- Web page managed by ATCSCC that provides information about current restrictions in the NAS including:
 - APREQs
 - MITS
 - Fix Closures
- Accessible at <http://www.fly.faa.gov/ois> > Current Restrictions
- Filter by requesting and providing facilities



ATCSCC
OIS
SYSTEM

5/16/2018

OIS Main Menu

- ☐ [NAS Status](#)
- ☐ [Int'l Status](#)
- ☐ [East Directory](#)
- ☐ [West Directory](#)
- ☐ [Airport Layout](#)
- ☐ Severe WX
- ☐ OPS Plans
- ☐ National Playbook
- ☐ [Tier Info](#)
- ☐ [Current Restrictions](#)

Current Restrictions

This page refreshes every minute. Last updated Wed, 16 May 2018 14:42:58 UTC

View restrictions **requested** by:

(List shows only facilities that have requested current restrictions)

ALL
 DCA
 N90
 PCT
 PHL

View restrictions **provided** by:

(List shows only facilities that have provided current restrictions)

ALL
 BWI
 CLT
 DCA
 EWR

Reset
Submit



- Filtering includes CLT or DFW as providing facilities and all requesting facilities
- Scrape HTML data for all 5 columns of the OIS table to use during parsing/interpretation

Current Restrictions

This page refreshes every minute. Last updated Wed, 16 May 2018 14:46:39 UTC

REQUESTING	PROVIDING	RESTRICTION	START TIME	STOP TIME
ZDC	CLT/ZTL	APREQ CLT,ZTL to DCA via BARMY,KILNS JETS 1130-0130 ZDC:CLT,ZTL	05/16/2018 1130	05/17/2018 0130
ZDC	CLT/ZTL	APREQ CLT,ZTL to EWR via BARMY,KILNS JETS 1015-0130 ZDC:CLT,ZTL	05/16/2018 1015	05/17/2018 0130
ZDC	CLT/ZTL	APREQ CLT,ZTL to IAD via BARMY,KILNS JETS 1330-2100 ZDC:CLT,ZTL	05/16/2018 1330	05/16/2018 2100
ZDC	CLT/ZTL	APREQ CLT,ZTL to LGA via BARMY,KILNS JETS 1015-0130 ZDC:CLT,ZTL	05/16/2018 1015	05/17/2018 0130
ZJX	CLT/ZTL	CLT SOUTHBOUND 10MIT SINGLE STREAM 1300-1600 ZJX:ZTL,CLT	05/16/2018 1300	05/16/2018 1600

- Parsed and interpreted data is stored in XML files for reference
- Contains original text from OIS page as well as interpreted data for comparison

